

## Polyvalent Crushing 20 - 45 HP

**Swing Flail Mower RBML115/130/155DG30**  
**Hydraulic Offset Kit DGH30 optional**  
 Microtractor 20 - 45 HP with power grip 540 tr/min  
 1 double acting control valve for hydraulic kit



Working width 115, 130 and 155 cm  
 Attelage arrière 3 points cat.1  
 Delivered with cardan shaft  
 Gearbox with freewheel  
 Adjustable offset 30 cm by mechanical indexing  
 Y - knives width 40 mm thickness 5 mm  
 Cutting height adjustable from -1.5 to 11cm depending on knife type (Y, hammer, paddles or scarificator)

**The advantages :**

**Substantial fuel savings due to the rotor design**

**Rotor with helical position:** *even drive without effort for optimal crush. Big rotor tube : cutting rigidity and inertia, electronic balancing after assembly of knives. Reduced energy consumption and CO2-emission*

**High rotation speed:** *rotation 2500 tr/min, cutting speed of 42m/s for a perfect cut and crush*

**System to avoid grass jam:** *no risk of grass winding around the roll*

**Curved chassis:** *the chassis form and the particular disposition of the back roll optimize the ventilation, ejection and self-cleaning of the roll* **Armoured sheet thickness 3 mm on model 155**

**Large opening:** *allows to swallow the vegetation without flatten*

**Drive:** 2 trapezoidal belts, adjustable tension can be controlled easily

**Security, ergonomic:** lateral deflectors adjustable, front flaps anti-projection, lifting eye in the centre of gravity for handling

Lubrication accessible without disassembly. Bearing and lubricators protected against impacts or cutting rejection.

**Option hydraulique :** Cylinder hoses with coupling 1/2" and valves for speed setting. Cylinder stroke 30 cm. A tractor with 2 double acting control valves is necessary

	(CV)	Number of tools			Overall dimensions	Weight (kg)
		"Y"	Paddles hammers	scarificators	L x l x h (cm)	
RBML115DG30	20/35	40	20	60	75 x 132 x 90	180
RBML130DG30	20/45	44	22	66	75 x 147 x 90	190
RBML155DG30	25/45	52	26	78	75 x 172 x 90	210

Serial Assembly with Y-knives

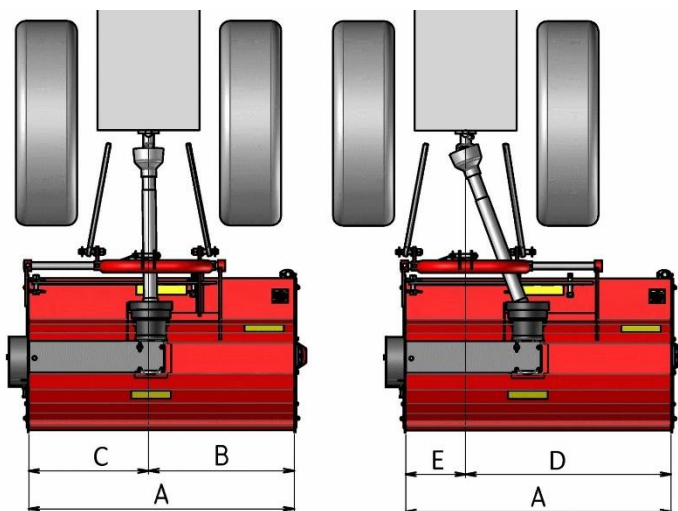

Optional assembly :

Paddles

hammers

scarificators

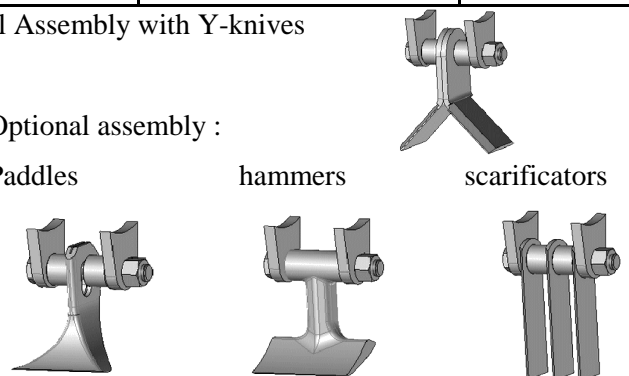

	A	B	C	D	E
RBML115DG30	115	55	60	85	30
RBML130DG30	130	70	60	100	30
RBML155DG30	155	77	78	107	48

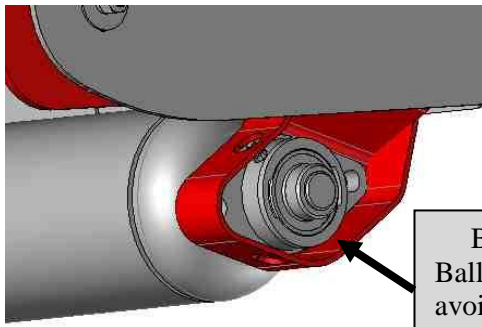

Back tyre :  
Ball bearing to  
avoid grass jam

Mud scraper on  
rotor to avoid  
grass jam

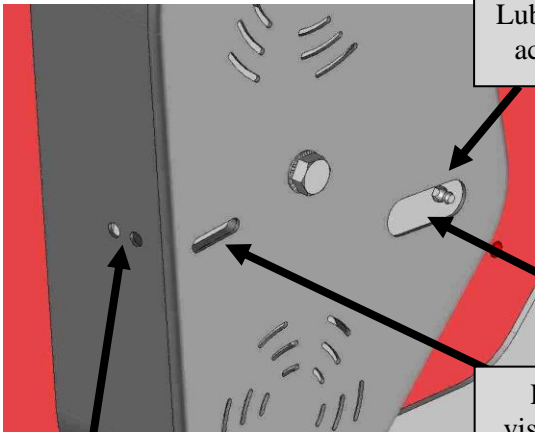
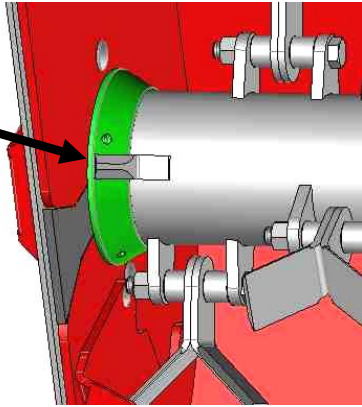

Lubrication  
accessible

Assembly  
pulley  
eccentric ring +  
keyway

Anti-intrusion  
roll fairing

Light to  
visualize the  
tension

Opening to press belts with  
screw driver

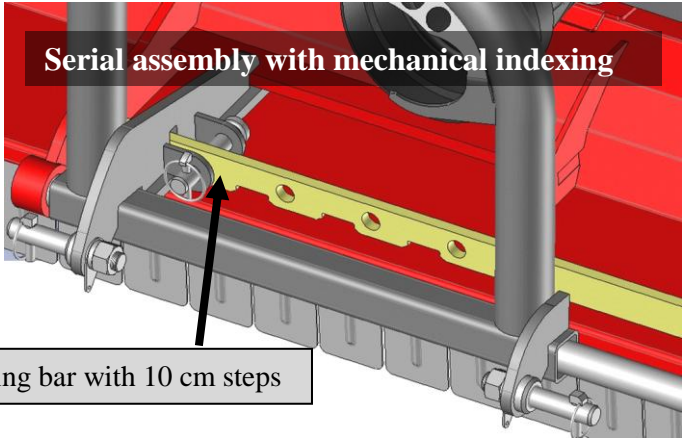
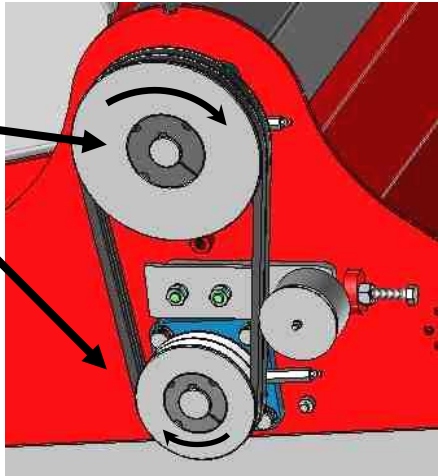

Adjusting bar with 10 cm steps

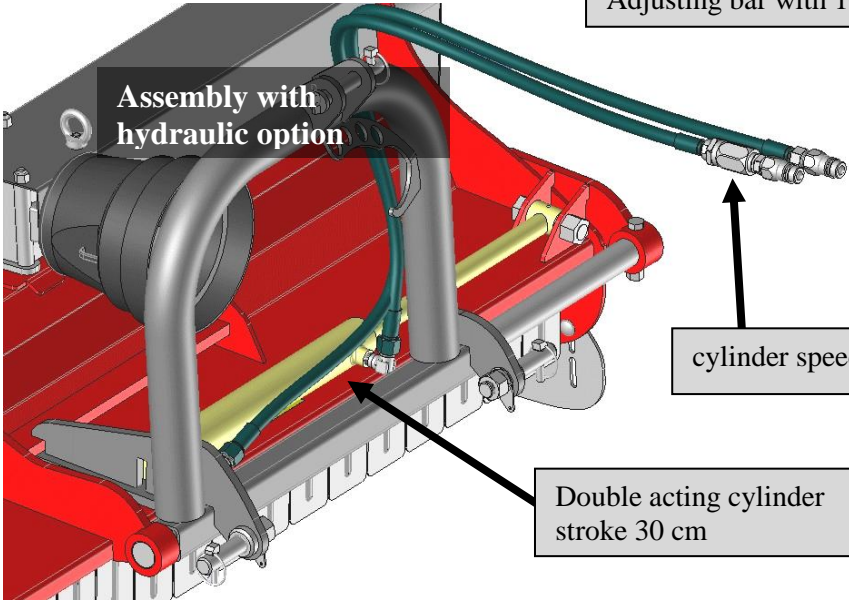

Assembly with  
hydraulic option

cylinder speed adjustment

Double acting cylinder  
stroke 30 cm